

QW-5957 Wash Entry System



Instruction Manual



Phone +64 3 338-3139
Anztec Ltd, PO Box 3288, Christchurch, New Zealand
www.anztec.com email sales@anztec.com

Features

- Accepts up to 6 denominations of coins
- Dispenses 2 denominations of coins
- Large customer information LCD
- Internal operator LCD
- 16 key operator keypad
- Receipt printer standard
- Fixed meters
- Resettable meters
- 3000 event log time and date stamped
- 4 malfunction alarm outputs
- Electronically monitored doors
- Total 8 mm stainless steel front door
- 5 mm heavy duty stainless steel cabinet
- Multipoint locking system
- 4 Illuminated vandal-resistant buttons
- Concrete reinforced stainless steel stand

Copyright

Copyright 2011 Anztec Ltd. This document is confidential. No part of this document may be reproduced, published or disclosed in whole or part, by any means: mechanical, electronic, photocopying, recording or otherwise without the prior written permission of Anztec Ltd. This document is made available under the terms of the confidentiality agreement signed with Anztec Ltd and must not be disclosed to any other person or organisation otherwise than as set out in the terms of that confidentiality agreement.

While every effort has been made to ensure that the information contained in this literature is accurate, Anztec Ltd reserves the right to amend the size and specifications of this machine in line with its policy of continuing improvement and development.

Contents

| | |
|-------------------------------------|-----------|
| FEATURES..... | 2 |
| CONTENTS..... | 3 |
| INSTALLATION | 5 |
| ESCROW CONNECTION | 5 |
| WASH START CONNECTIONS..... | 5 |
| WASH OPEN INTERFACE UNIT..... | 6 |
| MALFUNCTION ALARM OUTPUTS..... | 7 |
| <i>Output 1</i> | 7 |
| <i>Outputs 2, 3, + 4</i> | 7 |
| <i>Output 2</i> | 7 |
| <i>Output 3</i> | 8 |
| <i>Output 4</i> | 8 |
| SET UP | 9 |
| OVERVIEW | 9 |
| STARTUP | 9 |
| SERVICE MODE | 9 |
| SERVICE MODE MENU 1..... | 10 |
| RESET SYSTEM..... | 10 |
| SET TIME..... | 11 |
| SET DATE..... | 12 |
| SET UP RECEIPTS | 13 |
| <i>Wash Names</i> | 13 |
| <i>Site Name</i> | 13 |
| <i>Site Address</i> | 14 |
| <i>ABN/GST</i> | 14 |
| <i>Receipt Enable</i> | 15 |
| SERVICE MODE MENU 2..... | 16 |
| SET UP CORPORATE MODE | 16 |
| SET UP THE PRICING MENU | 16 |
| SET UP ESCROW..... | 17 |
| SERVICE MODE MENU 3..... | 18 |
| SET PULSE..... | 18 |
| SET UP COIN MECH..... | 18 |
| SET START MODE..... | 19 |
| SERVICE MODE MENU 4..... | 20 |
| RESTORE DEFAULT SETTINGS | 20 |
| SET START DELAY | 20 |
| SET NUMBER OF NOTE VALIDATORS | 20 |
| SERVICE MODE MENU 5..... | 21 |
| SET NOTE ACCEPTANCE..... | 21 |
| ADJUST THE CREDIT LIMIT..... | 21 |
| SET SECURITY LEVEL..... | 21 |

| | |
|---|-----------|
| SERVICE MODE MENU 6 | 22 |
| VALUE TOKENS..... | 22 |
| PRINTER..... | 23 |
| TERMINAL ENABLE..... | 23 |
| RETURN TO NORMAL OPERATION..... | 23 |
| DAILY MANAGEMENT | 24 |
| OVERVIEW..... | 24 |
| PRINT REPORTS..... | 24 |
| ACCOUNTANCY REPORT..... | 25 |
| EVENT LOG..... | 25 |
| FILL HOPPERS..... | 26 |
| RECORD HOPPER REFILLS..... | 26 |
| ADD COINS..... | 27 |
| ACCESS ACCOUNTANCY MODE..... | 27 |
| VIEW LONG OR SHORT TERM METERS..... | 28 |
| RESET SHORT TERM METERS..... | 29 |
| LEAVE ACCOUNTANCY MODE..... | 29 |
| ACCOUNTANCY METER LIST..... | 30 |
| ACCESS EVENT LOG..... | 31 |
| EVENT LIST..... | 32 |
| WASH OPEN INTERFACE UNIT | 33 |
| WASH INTERFACE UNIT SOFTWARE SETUP..... | 33 |
| NORMAL OPERATION | 34 |
| OVERVIEW..... | 34 |
| QW STAND | 35 |
| QW SURFACE MOUNT STAND | 36 |
| SPECIFICATIONS – QW-5957 | 37 |
| TECHNICAL SPECIFICATIONS..... | 37 |
| SOFTWARE SPECIFICATIONS..... | 38 |
| STAND SPECIFICATIONS..... | 38 |

Installation

Escrow Connection

This 24-volt AC or DC signal informs the entry system when a car is in the wash. Connect the escrow signal to the grey twin tru-rip. The escrow signal should be on when a car is in the wash and should drop out when the car leaves. This signal is debounced by the QW-5957.

Wash Start Connections

There are four normally open wash start relay contact outputs. The selected output will close for approximately 0.75 seconds in order to start the next wash. They are terminated as follows:

- Wash 1 - Black + Yellow
- Wash 2 - Black + Brown
- Wash 3 - Black + Pink
- Wash 4 - Black + Blue

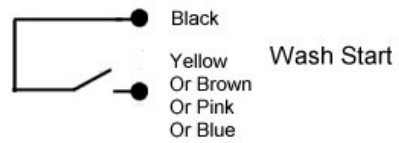

Wash Open Interface Unit

The Wash Open Interface Unit, in conjunction with a new version of software (version 4.20 or later) is able to detect the 'Wash Open' state of the Car Wash.

If the Car Wash is NOT supplying the correct 'Wash Open' signal to the Entry System, the Entry System will enter a disabled mode, and not accept any further transactions.

Locate the Wash Open Interface Unit. It is attached to the cover in the top right hand corner of the Quick Wash.

With the power off, remove the plastic cover to expose the connector terminal.



Feed the 24VAC wash start signal lines from your car wash through the hole in the Wash Open Interface Unit

Optional – remove the pcb from its box by removing the two securing screws – this may make fitting the cable easier in some circumstances



Connect 24VAC wash start signal lines from your car wash into connections 1 and 3 on connector S1 in the Wash Open Interface Unit

Cable tie the signal lines to the PCB using the holes supplied

Refit the cover.

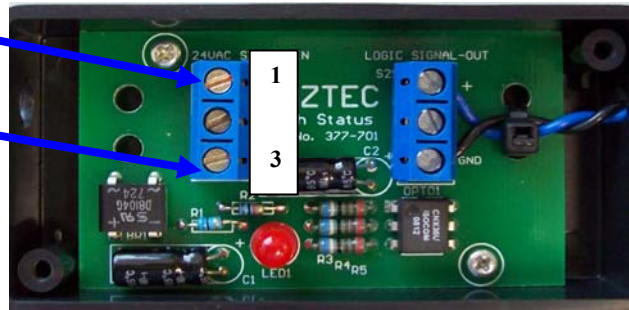
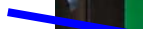

Refer to Wash Open Interface Unit instructions later in this document for configuration.

Malfunction Alarm Outputs

There are four relay outputs that may be used to inform an external dialler or security system of the status of the machine. To accommodate the maximum number of possible installation requirements, both normally open and normally closed outputs are supplied. The four outputs are labelled 1 through 4 and each comprises of a black common, one blue output and one pink output. If your dialler only has one input channel then you should connect it to output 1 as this channel activates when any error condition occurs.

On the other hand, if you require more specific error reporting, outputs 2, 3 and 4 allow you to activate a different message for each individual error.

Details of the individual alarm outputs are as follows:

Output 1

When the machine is operating normally, the hoppers have coins and the note validator has not reported a fatal error, the black common is shorted to the blue output line. Should a hopper run out of coins, the validator report a fatal error or the power fail, the black common will be shorted to the pink output wire.

The output will return to its no-fault status as soon as the relevant error condition is remedied.



Outputs 2, 3, + 4

These outputs work in the opposite sense to output 1. That is to say, they have the black common shorted to the pink output wire when there is no error and they switch over to the blue output to report a fault condition. Details of the individual outputs are listed below.

Output 2

This will connect the black and blue lines only when the validator reports a fatal note error. This condition will be reset when the main cabinet door is opened. When the validator is operating normally, the black and pink outputs will be connected. Note that a validator error will also cause output 1 to activate.

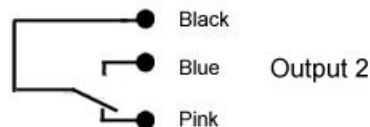

Output 3

This is the hopper status output. If a hopper runs empty, then the black and blue lines will be shorted. Otherwise, black and pink will be connected. Like output 2, this alarm will be reset when the main cabinet door is opened. Also like output 2, a hopper empty condition will cause output 1 to activate.

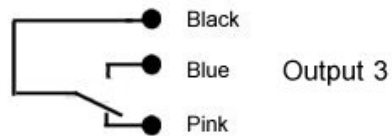

Output 4

This is the door open alarm. When the main cabinet door is closed the black common and the pink line will be shorted. This will swap over to the black and blue lines when the door is opened.

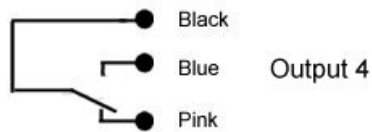

Set Up

Overview

When installing the QW-5957 as part of an automatic wash, there are several configuration parameters that must be set up in order for the machine to operate as intended. All of the configuration functions discussed below may be found on one of the six service mode menus.

Startup

To start the machine:

Unpack and install the equipment supplied.

Open the Main Door of the machine.

Connect to the mains supply.

Switch the unit on using the Mains Switch on the Power Supply front panel.

Service Mode

To activate service mode, insert the service mode key into the keyswitch located on the power supply tray and turn.

Once in service mode, pushing the “D” key will cycle you through the five service mode menus.

To exit service mode at any time, return the key to the upright position and withdraw it from the keyswitch.

Service Mode Menu 1

Immediately upon turning the service key, service mode 1 will be displayed, as shown:

```
SERVICE MODE MENU 1  A> SYSTEM RESET  
B> TIME/DATE         C> RECEIPT         D> MENU 2
```

Reset System

To reset the event log, and return the long term and short term accountancy meters to zero:

In Service Menu 1 press button A on the keypad.

```
****<<          SYSTEM RESET          >>****  
ENTER PIN NUMBER TO PROCEED
```

Enter the machine's PIN number on the keypad.

```
TO RESET, RETURN KEY TO OFF POSITION
```

Turn the Service Key to the OFF position to reset the system.

```
TO RESET, RETURN KEY TO OFF POSITION  
****<<          SYSTEM RESET          >>****
```

If you entered the PIN number incorrectly, turn off the Service Key switch and repeat the entire procedure.

Set Time

To set the time:

In Service Menu 1 press button B on the keypad to select set time/date.

Press button A to set the time.

```
SET TIME AND DATE MENU
A> SET TIME  B> SET DATE  C> EXIT
```

On the keypad, enter the hour, e.g., 09, and press #.

Enter the minute, e.g., 34, and press #.

Enter the seconds, e.g., 23, and press #.

Toggle between AM and PM by pressing any key, then press # to confirm your selection.

```
CURRENT TIME->12:55:23 PM
NEW TIME-> 0:00:00 AM
```

If this is not the correct time, press button B on the keypad and return to the set time and date menu.

If this is the correct time, press button A on the keypad.

```
NEW TIME-> 9:34:23 AM
IS THIS CORRECT? A=YES B=NO
```

When you have finished, press button B on the keypad to set the date, or button C to return to Service Mode.

Set Date

To set the date:

In Service Menu 1, press button B on the keypad to select set time/date.

Press button B to select the date.

```
SET TIME AND DATE MENU
A> SET TIME  B> SET DATE  C> EXIT
```

On the keypad, enter the day of the week by pressing a number between 01 (= Sunday) and 07 (= Saturday), and press #.

Enter the day, e.g., 04, and press #.

Enter the month, e.g., 02, and press #.

Enter the year, e.g., 03, and press #.

```
CURRENT DATE->WED 15/12/03
NEW DATE->??? 0/0/00
```

If this is not the correct date, press button B on the keypad and return to the set time and date menu.

If this is the correct date, press button A on the keypad.

```
NEW DATE->TUE 4/2/03
IS THIS CORRECT? A=YES B=NO
```

When you have finished, press button A on the keypad to set the time, or button C to return to Service Mode.

Set Up Receipts

To set the text that will be printed on the receipts:

In Service Menu 1, press button C on the keypad.

```
SERVICE MODE MENU 1  A> SYSTEM RESET
B> TIME/DATE         C> RECEIPT         D> MENU 2
```

Wash Names

You can name each of the four washes, e.g., Economy, Standard, Super, Wax, etc. Press button A to change the Wash Names.

```
RECEIPT SET UP MENU  A> WASH NAMES
B> SITE NAME         C> ADDRESS         D> MENU 2
```

Press button 1, 2, 3, or 4 to select the wash name you want to change.

```
WASH NAME SETUP
SELECT WASH NUMBER 1-4 OR HIT D TO EXIT
```

Use buttons * and # to move the cursor to the character you want to change. Use buttons A and B to scroll through the alphabet. When the cursor is on the letter you want, press # to set it. Repeat this for each letter you want to change.

```
USE A, B, *, # TO EDIT OR HIT D TO EXIT
WASH 1 NAME -> [□ , WASH 1...]
```

Press button D to exit.

Site Name

To change the Site Name enter the receipt setup menu and press button B.

Select the line of the site name you want to change

```
SITE NAME SETUP
SELECT LINE 1 OR 2, D TO EXIT
```

Use buttons * and # to move the cursor to the character you want to change. Use buttons A and B to scroll through the alphabet. When the cursor is on the letter you want, press # to set it. Repeat this for each letter you want to change.

```
USE A, B, *, # TO EDIT OR HIT D TO EXIT
SITE NAME -> [□ , SITE NAME...]
```

Press button D to exit.

Site Address

To add text to your Site Address, enter the receipt menu and press button C.

Select the line of the address you want to change

```
ADDRESS SET UP
SELECT ADDRESS LINE 1 OR 2, D TO EXIT
```

Use buttons * and # to move the cursor to the character you want to change. Use buttons A and B to scroll through the alphabet. When the cursor is on the letter you want, press # to set it. Repeat this for each letter you want to change.

```
USE A, B, *, # TO EDIT OR HIT D TO EXIT
ADDRESS LINE 1 -> [□ , ADDRESS LINE 1...]
```

Press button D to exit.

ABN/GST

To enter your ABN select option D – MENU 2 from the receipt setup menu.

```
RECEIPT SET UP MENU  A> WASH NAMES
B> SITE NAME  C> ADDRESS  D> MENU 2
```

Select option A – ABN

```
RECEIPT SET UP MENU 2          A> ABN
B> RECEIPT ENABLE      C> MENU 1    D> EXIT
```

This will display your current ABN and give you the option to edit it.

```
CURRENT ABN ->1234567890
HIT A TO EDIT ABN OR D TO EXIT
```

Press button A to edit the ABN

```
NEW ABN ->.....
TYPE IN NEW ABN - HIT # TO ENTER
```

Once the ABN is entered press # and select A or B to confirm.

```
NEW ABN ->.....XXXXXX.....
IS THIS CORRECT?  A>YES  B>NO
```

Press button D to exit.

Receipt Enable

To select the Receipt Enable option select option D – MENU 2 from the receipt setup menu.

Select B – Receipt Enable

```
RECEIPT SET UP MENU 2          A> ABN
B> RECEIPT ENABLE             C> MENU 1    D> EXIT
```

Press A to toggle receipt printing on or off.

```
RECEIPT PRINTING -> ON
PRESS A TO TOGGLE SETTING OR D TO EXIT
```

Press D to exit.

When you have finished setting up the receipts, return the Key Switch to the OFF position and remove the key.

Service Mode Menu 2

```
SERVICE MODE MENU 2  A> CORP MODE  
B> PRICING  C> ESCROW  D> MENU 3
```

Set Up Corporate Mode

This menu sets the way each wash can be purchased. There are two options:

NORM - a wash can be bought by cash or with a corporate token.

CORP - a wash can only be bought with a corporate token.

When cash is inserted into a terminal any wash set as CORP will not illuminate, and cannot be selected. This allows you to reserve certain washes for corporate use only.

To set up corporate mode:

In Service Menu 2 press button A on the keypad.

```
SELECT NEW SETTINGS OR HIT D TO EXIT  
1> NORM  2> NORM 3> NORM 4> CORP
```

The settings for each of the four washes are displayed. Use keys 1 to 4 to toggle the washes between Norm and Corp modes.

When you have finished, press button D on the keypad to exit, or return the Service Key Switch to the OFF position and remove the key.

Set Up The Pricing Menu

This menu sets the value of each wash.

To set up the pricing menu:

In Service Menu 2 press button B – Pricing on the keypad.

```
ENTER PRICE TO CHANGE OR HIT D TO EXIT  
1> $1.00  2> $2.00 3> $3.00 4> $4.00
```

The current prices for each of the four washes are displayed.

To change a wash price press the wash number on the keypad. A screen will show the current price and invite you to enter the new price.

```
CURRENT WASH 1 PRICE -> $1.00  
ENTER NEW PRICE ->$0.00
```

Type in the new price and press the # key when you have finished.

The new price confirmation screen will appear select A if the pricing is correct and B to return to the current pricing screen.

```
NEW WASH 1 PRICE ->$1.00
IS THIS CORRECT?  A> YES    B> NO
```

If you select A the pricing mode screen will display again, with the new price showing.

Change the other wash prices as required. When you have finished, press button D on the keypad to exit, or return the Service Key Switch to the OFF position and remove the key.

Set Up Escrow

"Escrow" refers to the number of cars that can be queued up for the car wash, including those waiting to pay and those that have paid.

To determine the escrow setting, count the number of car spaces between the entry booth and the wash. Count the space beside the entry booth too. If, for example, the entry booth is right outside the wash and the customer drives straight in after making a purchase then the escrow setting should be 1. If a customer purchases a wash and then enters a driveway long enough for two vehicles, the escrow setting should be 3.

To set escrow:

In Service Menu 2 press button C on the keypad.

```
CURRENT ESCROW SETTING -> 1 CARS
SELECT NEW SETTING OR HIT D TO EXIT
```

If the current escrow setting is correct, press button D on the keypad to exit, or return the Service Key Switch to the OFF position.

If the current escrow setting is NOT correct, type in the escrow value you want (you can select up to 5 cars), and exit.

Service Mode Menu 3

```
SERVICE MODE MENU 3  A> PULSE SET UP  
B> COIN MECH  C> START MODE  D> MENU 4
```

Set Pulse

You can set the width of the wash start pulse that the entry system sends to the carwash. It is set in 1/60th second units, e.g., a setting of 60 = 1 second, 30 = 1/2 second.

To set the pulse:

In Service Menu 3 press button A on the keypad.

```
CURRENT START PULSE WIDTH -> 0  
PRESS A TO CHANGE OR D TO EXIT
```

When you have finished, press button D on the keypad to exit, or return the Service Key Switch to the OFF position and remove the key.

Set Up Coin Mech

In coin mech mode you can set up the coin definitions for the coin mech channel. The terminal needs to know which denomination coin or token the coin mech is indicating when it toggles one of its output lines. A coin mech has 6 individual output lines. Each output line may be set up as 5 cents, 10 cents, 20 cents, 50 cents, \$1, \$2, one of four corporate tokens CT1, CT2, CT3, or CT4 or one of four value tokens VT1, VT2, VT3, or VT4.

To set up the coin mech:

In Service Menu 3 press button B on the keypad.

```
USE A, B, *, # TO SELECT OR HIT D TO EXIT  
1> 10C  2> 20C  3> 50C  4> $1  5> $2  6> 5C
```

The current settings for the six coin mech channels are displayed. The cursor will be by channel 1. Use the * and # keys to move the cursor to the other channels as required. Use the A and B keys to change the channel settings.

You can set a coin channel to CT1, CT2, CT3, or CT4 for corporate mode tokens 1 to 4. If a channel is set to CT1, for example, a pulse from the coin mech on this channel will cause the entry terminal to register a corporate token 1 input and start wash 1.

When a corporate token is accepted, the entry terminal will display "corporate mode" on the LCD. The LED beside the correct corporate mode wash will illuminate and the machine will wait for the customer to press the correct button.

Corporate customers cannot select change after inserting their token to be paid out in cash, nor can they select a different (cheaper) wash and be paid the difference.

When you configure the coin mech channels, you may find it useful to know which channel a currently accepted coin is programmed on. The coin mech is enabled when the terminal is in coin mech set up mode, so if you drop a coin through the mech the cursor will position itself beside the relevant coin mech channel. Use the A and B buttons on the keypad to enter the correct setting for that channel. Move the cursor to the correct channel manually using the * and # keys.

When you have finished, press button D on the keypad to exit, or return the Service Key Switch to the OFF position and remove the key.

Set Start Mode

You can set start mode to Auto or Manual. In Manual mode the customer inserts their currency and chooses from the available menu. In Auto mode, no choices are available to the customer. Once the customer has inserted enough money Wash 1 will start automatically and any change will be given.

To set the start mode:

In Service Menu 3 press button C on the keypad.

```
CURRENT START MODE -> MANUAL START  
PRESS A TO TOGGLE SETTING OR D TO EXIT
```

Press button A on the keypad to toggle between Manual and Auto.

When you have finished, press button D on the keypad to exit, or return the Service Key Switch to the OFF position and remove the key.

Service Mode Menu 4

```
SERVICE MODE MENU 4  A> REST DEFAULTS  
B> START DELAY  C> NOTE VAL  D> MENU 5
```

Restore Default Settings



Caution: Resetting the factory default settings will reset (clear) ALL of the configuration options detailed this guide. It does NOT clear short or long term meters or event log.

To reset the default settings:

In Service Menu 4 press button A on the keypad.

```
REST DEFAULT SETTINGS  ARE YOU SURE?  
A> YES  B> NO
```

Press button A on the keypad to restore default settings or press button B to leave settings as they are and exit Menu 4.

```
PLEASE WAIT  
RESTORING OPTIONS TO DEFAULT SETTINGS
```

Set Start Delay

You can set a start delay of between 1 and 10 seconds. Some carwashes cannot accept a start pulse immediately after completing the previous wash. This option can delay the next start pulse to give the carwash time to reset. It will not be necessary for most carwashes.

To set a start delay:

In Service Menu 4 press button B on the keypad.

Use button A to increment and B to decrement the start delay.

```
CURRENT START DELAY -> 0 SEC  
USE A AND B TO SELECT OR HIT D TO EXIT
```

When you have finished, press button D on the keypad to exit, or return the Service Key Switch to the OFF position and remove the key.

Set Number of Note Validators

This feature is now disabled.

Service Mode Menu 5

```
SERVICE MENU MODE 5  A> NOTE ACCEPTANCE  
B> CREDIT LIMIT  C> SECURITY  D> MENU 6
```

Set Note Acceptance

You can set the denominations of notes the machine can accept.

In Service Menu 5 press button A on the keypad.

```
USE KEYS 1 - 5 TO TOGGLE - HIT D TO EXIT  
$5 ON $10 ON $20 ON $50 ON $100 ON
```

Each denomination is assigned a number key. 1 = \$5, 2 = \$10, 3 = \$20, 4 = \$50, 5 = \$100.

Press the number key assigned to each denomination to toggle it ON or OFF.

When you have finished, press button D on the keypad to exit, or return the Service Key Switch to the OFF position and remove the key.

Adjust the Credit Limit

You can adjust the credit limit. Once the limit you set has been reached, the machine will not accept any more money until after a wash has been purchased, or change paid out.

To adjust the credit limit:

In Service Menu 5 press button B on the keypad.

```
CURRENT CREDIT LIMIT -> $20  
HIT A TO ADJUST OR D TO EXIT
```

When you have finished, press button D on the keypad to exit, or return the Service Key Switch to the OFF position and remove the key.

Set Security Level

You can select either a Normal or High security level.

In Service Menu 5 press button C on the keypad.

```
VALIDATOR SECURITY MODE: NORMAL  
PRESS A TO TOGGLE SETTING OR D TO EXIT
```

Press button A on the keypad to toggle between Normal or High security.

When you have finished, press button D on the keypad to exit, or return the Service Key Switch to the OFF position and remove the key.

Service Mode Menu 6

```
SERVICE MENU MODE 6          A>VALUE TOKENS  
B> PRINTER    C> TERMINAL ENABLE  D> MENU 1
```

Value Tokens

This menu sets the value of each Value Token.

To set up the pricing menu:

In Service Menu 6 press button A – Value Tokens.

```
ENTER TOKEN TO CHANGE OR HIT D TO EXIT  
1> $1.00  2> $2.00  3> $3.00  4> $4.00
```

The current prices for each of the four tokens are displayed.

To change a token value, press the token number on the keypad. A screen will show the current price and invite you to enter the new price.

```
CURRENT VAL TOKEN 1 VALUE -> $1.00  
ENTER NEW VALUE ->$0.00
```

Type in the new price and press the # key when you have finished.

The new price confirmation screen will appear select A if the pricing is correct and B to return to the current pricing screen.

```
NEW VAL TOKEN 1 VALUE ->$1.00  
IS THIS CORRECT?  A> YES    B> NO
```

If you select A the token value screen will display again, with the new price showing.

Change the other token values as required.

Note: You must return to the *setup coin mech* section and assign the Value Tokens to channels in the coin mech in order to implement Value Tokens.

When you have finished, press button D on the keypad to exit, or return the Service Key Switch to the OFF position and remove the key.

Printer

To set printer type:

In Service Menu 6 press button B on the keypad.

Use button A , B and C to select the printer type.

```
CURRENT PRINTER TYPE -> SEIKO
USE A, B AND C TO SELECT OR HIT D TO EXIT
```

When you have finished, press button D on the keypad to exit, or return the Service Key Switch to the OFF position and remove the key.

Terminal Enable

The Terminal Enable setting allows the Wash Open Interface Unit to operate.

In Service Menu 6 press button C on the keypad.

To allow the Wash Open Interface Unit to operate set the terminal enable input to ON.

```
TERMINAL ENABLE INPUT -> OFF
PRESS A TO TOGGLE SETTING OR D TO EXIT
```

When you have finished, press button D on the keypad to exit, or return the Service Key Switch to the OFF position and remove the key.

Return to Normal Operation

To leave Service Mode and return to Normal Operation Mode:

Turn the Service Key to the OFF position and remove it.

```
PUSH ANY KEY TO ENTER ATTENDANT MODE
TOTAL CREDITS $0.00
```

You can now either shut the door, or leave it open and monitor transaction progress on the display.

Remember to remove the Service Key before attempting to close the Main Door.

Daily Management

Overview

Once you have installed the **Quick Wash**, you can enter Attendant Mode to perform any of the following functions whenever required:

- Print reports, including the event log and accountancy.
- Fill the hoppers and record hopper refills,
- Access the accountancy meters.
- Access the event log

When the **Quick Wash** is in Attendant Mode, it does not accept notes or coins. The following daily management instructions show you how to perform these functions.

Print Reports

You can cancel this procedure at any time by shutting the Main Door. To print a report:

Open the Main Door.

```
PUSH ANY KEY TO ENTER ATTENDANT MODE
TOTAL CREDITS $0.00
```

Press any key on the keypad.

```
<<ATTENDANT MODE>>
```

```
SELECT A FUNCTION:  A> PRINT REPORTS
B> REFILL  C> ACCOUNTANCY  D> EVENT LOG
```

Press button A on the keypad.

```
WHICH REPORT DO YOU WANT TO PRINT?
A>ACCOUNTANCY  B>EVENT LOG  C>EXIT
```

Accountancy Report

To print the accountancy report, press button A on the keypad at step 3 in Print Reports. The **Quick Wash** will print a full accountancy report containing both short and long term meters.

```
PRINTING ACCOUNTANCY REPORT
```

When the printer has finished printing:

```
SELECT A FUNCTION: A>PRINT REPORTS  
B>REFILL C>ACCOUNTANCY D>EVENT LOG
```

Select another function or close the Main Door to exit.

Event Log

To print the event log, press button B on the keypad at step 3 in Print Reports to move to the following screen:

```
SELECT EVENTS TO PRINT A>ALL EVENTS  
B>NEW EVENTS C>ENTER # D>EXIT
```

If you want to print a complete event log of up to 3000 events, press button A on the keypad to start printing.

If you want to print all events since the last report was printed, press button B on the keypad to start printing.

If you want to print a specific number of events, press button C on the keypad.

```
EVENTS TO PRINT->0  
ENTER THE NUMBER OF EVENTS TO PRINT
```

On the keypad, enter the number of events you want to print.

```
EVENTS TO PRINT->10  
PRESS THE # BUTTON TO ENTER THE VALUE
```

Press # to start the printer. When the printer has finished printing:

```
SELECT A FUNCTION: A> PRINT REPORTS  
B> REFILL C> ACCOUNTANCY D> EVENT LOG
```

When you have finished printing reports, select another function, or close the Main Door to exit.

Fill Hoppers

To fill the hoppers, you need to:

- Record the value of the refills, and
- Add coins to the hoppers.

Record Hopper Refills

Note that you can cancel this procedure at any time by shutting the Main Door. To record the value of the refills:

Open the Main Door.

```
PUSH ANY KEY TO ENTER ATTENDANT MODE
TOTAL CREDITS $0.00
```

Press any key on the keypad.

```
<<ATTENDANT MODE>>
```

```
SELECT A FUNCTION:  A> PRINT REPORTS
B> REFILL  C> ACCOUNTANCY  D> EVENT LOG
```

Press button B on the keypad.

```
****<<REFILL MODE>>****
ENTER THE HOPPER NUMBER TO BE REFILLED
```

Enter the number of the hopper you want to refill (1 or 2).

```
REFILL HOPPER 1->$0.00
ENTER THE REFILL AMOUNT IN DOLLARS
```

Enter the value of the refill, e.g., 1000.00.

```
REFILL HOPPER 1->$1,000.00
PUSH THE # BUTTON TO ENTER THE VALUE
```

Press #.

```
REFILL HOPPER 1 WITH $1,000.00
IS THIS CORRECT? A=YES B=NO
```

If this is not the correct refill value, press button B on the keypad and return to step 5.
If this is the correct refill value, press button A on the keypad.

```
****<REFILL RECORDED>****
```

```
<<ATTENDANT MODE>>
```

```
SELECT A FUNCTION:  A> PRINT REPORTS  
B> REFILL  C> ACCOUNTANCY  D> EVENT LOG
```

If you want to refill the other hopper, repeat from step 3 above. When you have finished recording hopper refills, select another function, or close the Main Door.

Add Coins

To add coins to the hopper:

- Check that there are no rubber bands, coin bags, or other foreign bodies in with the coins.
- Check that you are placing the correct denomination of coins into the correct hopper.
- Pour the coins into the hopper.

Access Accountancy Mode

The **Quick Wash** has 32 electronic meters, which you can access while in Accountancy Mode. This mode over-rides all functions other than Service Mode (the event log still functions).

In Accountancy Mode, you can zero all the short-term accountancy meters except the hopper level meters.

To print the accountancy report, which contains all meter readings, refer to *Print Reports*.

Note that you can exit the accountancy meters at any time by shutting the Main Door, or by pressing button D on the keypad.

View Long or Short Term Meters

To view the long or short term accountancy meters:

Open the Main Door.

```
PUSH ANY KEY TO ENTER ATTENDANT MODE
TOTAL CREDITS $0.00
```

Press any key on the keypad.

```
<<ATTENDANT MODE>>
```

```
SELECT A FUNCTION:  A> PRINT REPORTS
B> REFILL  C> ACCOUNTANCY  D> EVENT LOG
```

Press button C on the keypad.

```
-----<<ACCOUNTANCY MODE>>-----
```

```
SELECT LONG TERM OR SHORT TERM METERS
A> LONG TERM  B> SHORT TERM
```

Select the type of meter you want to view by pressing either button A or B on the keypad.

```
SHORT TERM METER 1 ->HOPPER 1 LEVEL
0 COINS          $0.00
```

For either long or short term meters, use the * and # buttons on the keypad to view meters 1 to 20:

* button: to move backwards through the 20 meters

button: to move forwards through the 20 meters

To exit, press D on the keypad to return to select a function screen (in Step 2).

Reset Short Term Meters

You can only reset short term meters when you are in short term meter mode.

To reset all short term meters except the hopper level meters to zero, press button A on the keypad.

```
CLEAR SHORT TERM METERS?  
A > YES  B > NO
```

To clear short term meters, press button A on the keypad.

```
***<SHORT TERM METERS CLEARED>***
```

Leave Accountancy Mode

When you have finished viewing the accountancy meters, press button D on the keypad.

```
<<ATTENDANT MODE>>
```

```
SELECT A FUNCTION:  A> PRINT REPORTS  
B> REFILL  C> ACCOUNTANCY  D> EVENT LOG
```

Select another function, or close the Main Door.

Accountancy Meter List

| | Meter No. | |
|--|-----------|------------------------|
| Washes Cash: | 1 | Wash 1 Cash |
| | 2 | Wash 2 Cash |
| | 3 | Wash 3 Cash |
| | 4 | Wash 4 Cash |
| Total cash washes: | 5 | Total cash washes |
| Washes Credit: | 6 | Wash 1 Credit |
| | 7 | Wash 2 Credit |
| | 8 | Wash 3 Credit |
| | 9 | Wash 4 Credit |
| Total credit washes: | 10 | Total credit washes |
| Hopper levels: | 11 | Hopper 1 level |
| | 12 | Hopper 2 level |
| | 13 | Hopper 1 refill |
| | 14 | Hopper 2 refill |
| Number and value of coins in: | 15 | 5 c |
| | 16 | 10 c |
| | 17 | 20 c |
| | 18 | 50 c |
| | 19 | \$1 |
| | 20 | \$2 |
| Value of total coins in: | 21 | Total coins |
| Number and value of corporate tokens in: | 22 | Corp token 1 |
| | 23 | Corp token 2 |
| | 24 | Corp token 3 |
| | 25 | Corp token 4 |
| Value of total corporate tokens in: | 26 | Total corporate tokens |
| Number and value of Value tokens in: | 27 | Value token 1 |
| | 28 | Value token 2 |
| | 29 | Value token 3 |
| | 30 | Value token 4 |
| Value of total Value tokens in: | 31 | Total value tokens |
| Number and value of notes in: | 32 | \$5.00 |
| | 33 | \$10.00 |
| | 34 | \$20.00 |
| | 35 | \$50.00 |
| | 36 | \$100.00 |
| Value of total notes in: | 37 | Total notes in |
| Value of total credit in: | 38 | Total credit in |
| Total value in: | 39 | Grand total in |
| Payouts: | 40 | Hopper 1 paid out |
| | 41 | Hopper 2 paid out |
| Value of total coins out | 42 | Total coins out |
| Total value out: | 43 | Grand total out |

Access Event Log

The **Quick Wash** event log records the last 3000 events, along with the date and time they occur. For example, the event log records when:

- The door is opened or closed,
- Notes or coins are inserted,
- Change is dispensed,
- Power is turned on,
- Any hopper is refilled.

You can access the event log by opening the Main Door (the **Quick Wash** continues to monitor machine functions while in this mode). Note that you can exit the event log at any time by shutting the Main Door. To access the event log:
Open the Main Door.

```
PUSH ANY KEY TO ENTER ATTENDANT MODE
TOTAL CREDITS $0.00
```

Press any key on the keypad.

```
<<ATTENDANT MODE>>
```

```
SELECT A FUNCTION:  A> PRINT REPORTS
                    B> REFILL  C> ACCOUNTANCY  D> EVENT LOG
```

Press button D on the keypad.

```
--<<EVENT LOG MODE>>--
```

The **Quick Wash** displays the most recent event, for example:

```
EVENT LOG  TUE 4/2/03  10:05:48 PM
$20 NOTE ACCEPT      - CREDIT -> $20.00
```

Tap the * and # buttons on the keypad to view each event in the event log:

* button: to move backwards through the event log

button: to move forwards through the event log

When you have finished reading the event log, press button D on the keypad.

```
<<ATTENDANT MODE>>
```

```
SELECT A FUNCTION:  A> PRINT REPORTS
                    B> REFILL  C> ACCOUNTANCY  D> EVENT LOG
```

Select another function, or close the Main Door.

Event List

The following is a list of the events recorded by the event log (along with time and date stamp).

| | |
|-----------|---|
| Doors | Main door opened Main door closed |
| Hoppers | Hopper 1 empty Hopper 2 empty All hoppers empty Hopper 1 refill Hopper 2 refill |
| Coins In | Coin in channel 1 Coin in channel 2 Coin in channel 3 Coin in channel 4 Coin in channel 5 Coin in channel 6 |
| Notes In | Note in channel 1 Note in channel 2 Note in channel 3 Note in channel 4 Note in channel 5 Validator cheated Note jammed Validator faulty |
| Coins Out | Coins out hopper 1 Coins out hopper 2 |
| System | Machine powered up System clear Short term meter clear Accountancy report printed System time set System date set |

Wash Open Interface Unit

The Wash Open Interface Unit is a printed circuit board housed in a plastic case mounted inside the QW-5957 Entry System. This detects the operational status of the car wash and prevents the entry system from selling a wash in the event the wash is disabled for any reason.

Wash Interface Unit Software Setup

Open the door of the Entry System and turn the attendant key on the power supply.

This will enter Service Mode. You will see the following screen:

```
SERVICE MODE MENU 1  A> SYSTEM RESET  
B> TIME / DATE      C> RECEIPT  D> MENU 2
```

Press D five times, to get to Menu 6. You will see the following screen:

```
SERVICE MODE MENU 6  A> VALUE TOKENS  
B>PRINTER  C>TERMINAL ENABLE D>MENU 1
```

Press C on the keypad to enter the Terminal Enable setting menu. You will see the following screen:

```
TERMINAL ENABLE INPUT -> OFF  
PRESS A TO TOGGLE SETTING OR D TO EXIT
```

The Terminal Enable Input setting is OFF by default (ie. ignore Wash Open signals from the car wash)

To enable the Wash Open/Closed operation (ie. respond to Wash Open signals from the car wash) , press A on the keypad.

The terminal enable setting will now be ON (as shown on the top line of the display.)

```
TERMINAL ENABLE INPUT -> ON  
PRESS A TO TOGGLE SETTING OR D TO EXIT
```

Once the Press D to exit. You will be returned to SERVICE MODE MENU 6 Screen.

Switch off the attendant key and close the Entry System door to return to normal operation.

Normal Operation

Overview

The customer arrives at the **Quick Wash**, and inserts money into the slot.

The customer selects the wash they require by pressing the illuminated button beside it.

If a token is used, only the wash set by the token will be illuminated and able to be selected.

The customer can cancel by pressing the red illuminated button. Their cash will be returned as change. There are NO refunds on tokens.

The red button flashes and the screen displays a message asking the customer to press the flashing button if they would like a receipt.

The Quick Wash prints the receipt if requested when using cash.

The screen then directs the customer to move forward.

QW Stand

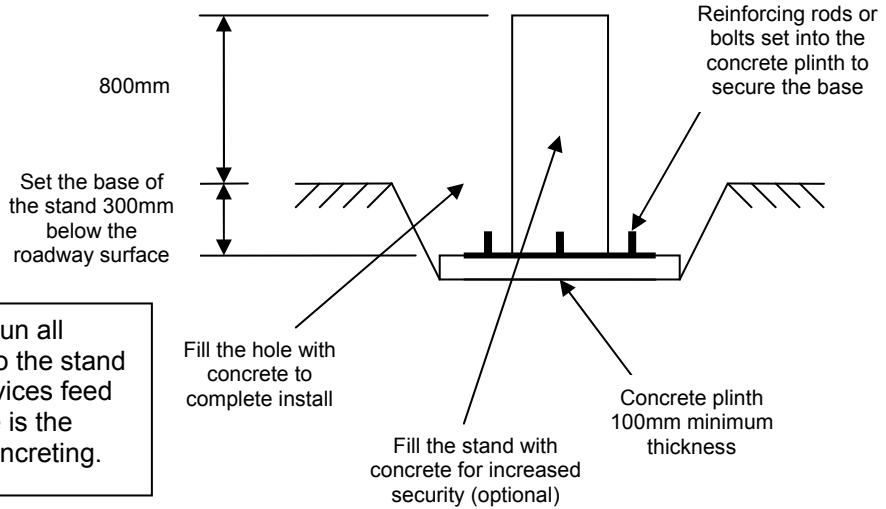

Note: Make sure you have run all services through the plinth to the stand and into the rectangular services feed cutout area. Check the base is the correct orientation before concreting.

Base Plate Dimensions

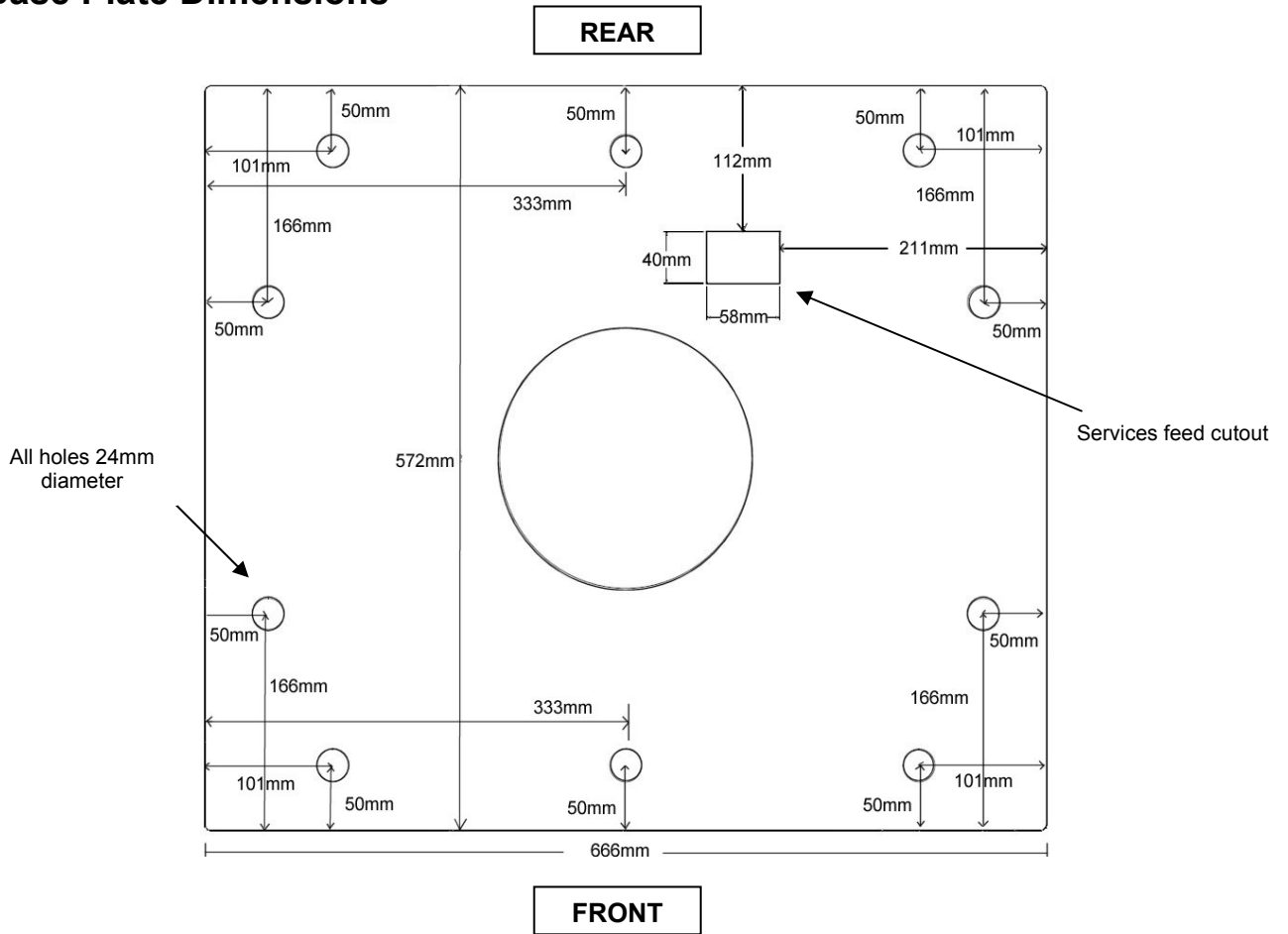

QW Surface Mount Stand



Fill the stand with concrete for increased security (optional)

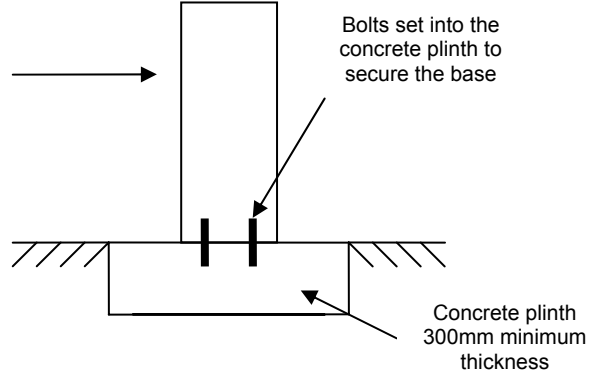

Note: Make sure you have run all services through the plinth to the stand and into the circular services feed cutout area. Check the base is the correct orientation before concreting.

Base Mounting Dimensions

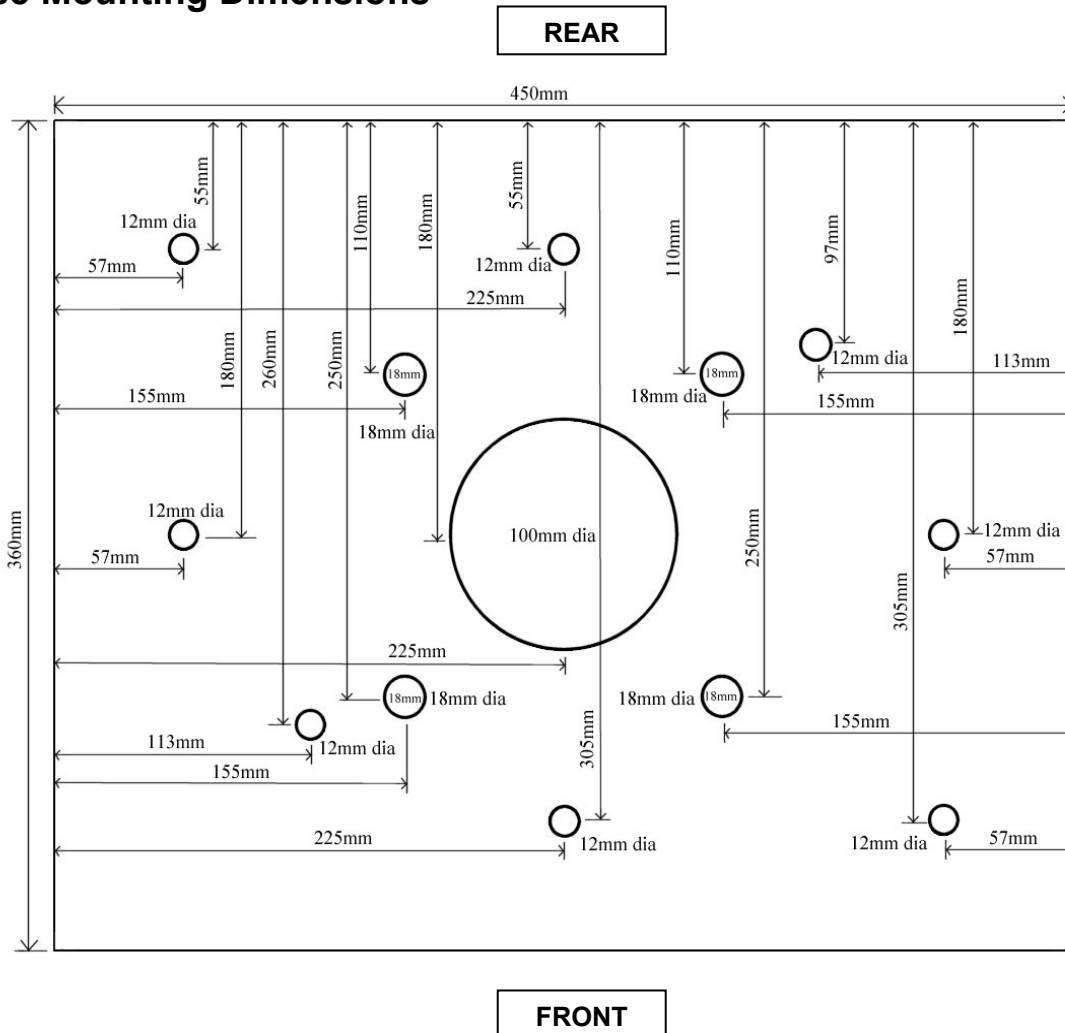

Specifications – QW-5957

Technical Specifications

| | | |
|--------------------------|---|---------------------|
| Electrical Specification | Nominal Mains Input Voltage: | 110/240 V AC |
| | Frequency: | 50/60 Hz |
| | Mains supply current (max.): | 1.6 A |
| Operating Environment | Minimum temperature: | 0°C |
| | Maximum temperature: | 50°C |
| | Relative humidity (min.): | 10% |
| | Relative humidity (max.): | 95% |
| Cabinet | Dimensions (mm) (H x W x D): | 750 x 475 x 380 |
| | Weight (kg): | 90 |
| | Total 8 mm stainless steel front door. | |
| | Multipoint locking mechanism. | |
| | Secure coin presentation mechanism. | |
| | Monitored door. Compact footprint. | |
| Hoppers | Two Coin Controls Universal MK4 Hoppers. | |
| | Payout speed: | 12 coins per second |
| | Capacity (21 mm coins): | 4,000 |
| Credit Card Reader | None | |
| Operator Display | Two lines x 40 character wide, back-lit LCD (Liquid Crystal Display). | |
| Customer Display | Two lines x 20 character wide, back-lit LCD (Liquid Crystal Display). | |
| Coin Acceptor | Standard unit includes a Microcoin QL electronic coin mechanism, accepting up to six denominations. | |
| Note Validator | MEI Bank Note Validator . | |
| Operator Control | 16 button alphanumeric keypad for entering all refills, PIN numbers, etc. | |
| Printer | Seiko receipt printer, 130 mm roll. | |
| Communications | Three serial ports available for communication with devices such as monitoring systems, printers, validators, bonus prize systems, smart/swipe card reader/writers and camera security systems. | |
| | Each serial port can be configured with either RS 232 or RS 485/422 drivers. | |
| Real Time Clock | Real time clock supplies time/date stamp information for various logging functions. | |
| | Battery back-up maintains time in the absence of mains supply, for more than three months. | |
| Security | Switch detection of opening or closing of the main door. | |
| | Cabinet specifications 5 mm stainless steel, total 8 mm front door. | |
| | Multipoint locking system. | |
| | Optional ESM (Extra Security Module) is available, which detects and time/date-stamps the following events when the power is disconnected: | |
| | Door opens Illuminated vandal-resistant buttons. | |

Software Specifications

| | |
|-------------------------------|---|
| Refills | Refills are either variable or fixed value (determined at set-up). All refills time/date-stamped and recorded in a log, which can be printed or downloaded to the monitoring system at any time. |
| Event Log | Full regression analysis: all transaction details such as notes/coins in, and coins out, are logged, so that a full audit trail is available to the operator. The log can store up to 3000 customer transactions, refill details, door opens, etc. All events are time/date-stamped. |
| PIN Security | In high security applications, individual operators can have their own operator identification number and corresponding PIN number. When the PIN Security feature is enabled, operators must enter their PIN number when attending to the machine (to re-activate transaction mode). The system records the operator identification number against the time/date-stamped event, so that full accountability is assured. |
| Metering | The system features two full sets of meters for short and long term totals. There is a meter for each individual coin and note denomination, as well as summarised totals and current hopper level indicators. Short-term meters can be cleared daily, weekly, or as required. Meters can be read on the LCD or printed out. |
| Applications | Various software implementations are available to cover a full range of applications. Software versions are available for gaming, amusement, and vending installations. Custom software can be supplied on request. |
| Remote Monitoring | The event log and all meter activity data can be sent to a PC or other monitoring system for remote monitoring. |
| Malfunction Alarm Outputs x 4 | Connect to an external dialer via security system to inform the operator of the status of the machine. |

Stand Specifications

| | | |
|------------------------|---|------------------------|
| QW Stand | Dimensions (mm) (H x W x D), not including footplate: Weight (kg): | 1100 x 460 x 370 40 |
| QW Surface Mount Stand | Dimensions (mm) (H x W x D), Weight (kg): | 825 x 460 x 370 30 |

Anztec reserves the right to change the specifications and features of the **Quick Wash** without notice.